

JOHNS HOPKINS
UNIVERSITY

INTO AFRICA

**FREE
ROUND-TRIP
AIRFARE!**

**Explore West Africa's
Hidden Treasures on
Voyages between
Cape Town, Accra, and
the Strait of Gibraltar**

**Aboard the All-Suite,
100-Guest *Corinthian***

February 17 - March 8, 2013

March 5 - 24, 2013

Grand Voyage: February 17 - March 24, 2013

NO SINGLE SUPPLEMENT for Solo Travelers



The voyages described in this brochure are to an “undiscovered” Africa, an Africa of souks and bazaars, of vanished empires and colonial plantations, of pristine tropical islands, lush rain forests, and immense, starkly beautiful deserts. And since this is Africa, there is wildlife—an astonishingly rich variety of wildlife. All of this, and much more, you will find along the shores of West Africa.

It’s ironic that West Africa, once busy with the ships of explorers, colonists, traders, and missionaries, is rarely visited by contemporary travelers. With these voyages that encompass the continent’s entire coast between the Cape of Good Hope in South Africa and the Strait of Gibraltar, we hope to change that.

In fact, traveling by ship is the only way such unique journeys are possible, as air and land connections between South Africa and North Africa are logistically complex and time-consuming. Aboard ship, you unpack once and travel in perfect comfort.

One of our goals is to introduce you to the many different “Africas”: the noble Imperial cities of Morocco; the handsome colonial monuments of Luanda, Angola; the lush forests and wildlife sanctuaries of The Gambia, Sierra Leone, and Ghana; the idyllic islands of São Tomé and Príncipe; the world-class wineries of South Africa.



DISCOVER *the* UNKNOWN SHORES *of* AFRICA

These voyages give you rare opportunities to get to know the people of Africa. We'll meet local artists and artisans, fishermen and farmers, wildlife park rangers, and the staff of the Tacugama chimpanzee rescue program. To deepen your understanding of contemporary Africa, we will also arrange discussions with local leaders.

Like you, we are aware of the demands group travel can make on local environments. That is why we travel only on a small ship with a limited number of participants. "Traveling small" enables us to visit sites that would be out of bounds to the thousands of passengers from massive cruise ships. When we visit a traditional village, a wildlife park, or a cultural monument, we do not overwhelm it, and we are careful to minimize as much as possible our impact on the site.

Our ship, the *Corinthian*, is ideal for this unprecedented voyage. With only 50 spacious suites, many with a private balcony, elegant common areas, superb facilities, expansive promenade decks, and almost as many crew members as guests, *Corinthian* adds immeasurably to the success of the discovery of West Africa. For most travelers, a voyage to Africa is a once-in-a-lifetime opportunity. To make the experience even more memorable for you, we have arranged a tremendous variety of exciting destinations, one-of-a-kind happenings, and unforgettable activities. Join us aboard *Corinthian* to discover the secret treasures of Africa.

*This page: West Africa's coast is lined with pristine waterways
Cover: Red colobus monkeys, Abuko Nature Reserve, The Gambia*

EXPERIENCE *a* NEW WORLD *in* WEST AFRICA

Many Americans are familiar with the savannas and the wildlife of East Africa. West Africa, however, is virtually unknown to even the most experienced travelers. Yet the natural history of West Africa is more diverse, often more lush, and in many ways as exciting as that of East Africa.

For example, along the coastlands of Morocco you'll find flourishing vineyards and olive and orange groves, while the country's North Sahara region is a vast, dramatic desert. And towering over all are the serrated peaks of the Atlas and Rif mountains.

The low-lying regions of The Gambia are mainly woodlands and wetlands—ideal habitats for birds such as storks, egrets, and crested cranes, as well as primates such as baboons and western red colobus monkeys.

The islands of São Tomé and Príncipe are an unspoiled tropical paradise, a place so rarely visited by travelers that you may have one of the islands' pristine, palm-fringed beaches all to yourself.

The Namib Desert is the oldest desert in the world, formed about 80 million years ago. Yet there is a strange beauty to this stark landscape of sand, stone, and mountain peaks. And it is full of life—including oryxes, ostriches, and black-backed jackals.

Every day on this voyage will bring a new discovery.



THE CULTURE *of* WEST AFRICA—FAR BEYOND THE ORDINARY

It would be the work of a lifetime to catalog the cultures of West Africa: the indigenous and the colonial, the ancient and the modern, the religious and the secular.

On Lake Togo you'll travel from village to village by pirogue—still the primary form of transportation along the lake—visiting fishermen and farmers who have embraced some aspects of modern life, but still practice the traditions of their ancestors.

The plantations of São Tomé, the distinctive French architecture of Porto-Novo in Benin, the castles along Ghana's Gold Coast, the churches and fortresses of Angola, all recall the days when much of West Africa was in the hands of European nations. Even today, many West Africans can speak French or English or Portuguese in addition to their native language.

We have selected our destinations carefully so you can observe the real life of the people of West Africa—in their villages, their markets, and their workplaces.

RESPONSIBLE TRAVEL

We treasure the places we visit and respect the people and wildlife who live there. We are committed to protecting the environment and the cultural heritage of our destinations, while encouraging economic opportunities for the residents of these priceless, unforgettable regions of the earth. We contribute to organizations that work to protect endangered species, preserve biodiversity, help communities become economically sustainable in an eco-friendly way, and reduce the carbon footprint of travelers to the region.

*Ganvié, Benin, Africa's largest lake village,
with over 15,000 people living in stilt houses*





*Traditional dance performance
in Porto-Novo, Benin*

TRAVEL AND LEARN *with a TEAM of EXPERTS*

Each voyage is accompanied by an experienced team of expedition staff and lecturers who are intimately familiar with our destinations. Through lectures and discussions, they will introduce you to the culture, history, and wildlife of these unforgettable lands. You will discover the wondrous variety of life in the rain forests, islands, and deserts we visit. You will also experience the rich diversity of cultures shaped by a variety of indigenous peoples and colonial powers, and pursuing a variety of social and political paths since independence. Among the experts you may travel with are:



Following years of experience at the Eastern Cape Nature Conservation, **Marius Burger** has worked as a herpetologist and faunal specialist with a number of environmental organizations around Africa. He has

collaborated with the Smithsonian Institution and WWF-USA in Gabon and the Central African Republic. The author of numerous books, articles, and papers on natural history and conservation topics, he lectures widely and has been a presenter on television nature programs, including on National Geographic and BBC World.



Vincent Resh has been a professor of Environmental Science, Policy and Management at the University of California, Berkeley, since 1975. A world authority on rivers, he was the senior advisor on water

and environmental sustainability for the World Health Organization in 11 West African countries for 15 years. He has written and lectured extensively on the areas to be visited on this exciting trip and has led many trips to Africa.



Saskia Travert grew up on Reunion Island, just off the coast of Madagascar. After working for private game lodges in Kruger National Park, she has also been an expedition staff member in Antarctica and the Arctic.

Saskia continues pursuing her lifelong passion for Africa's fauna and flora, having recently worked along the shores of South Africa, Mozambique, Madagascar, and the Seychelles.



Expedition Leader **Peter Graham's** many years of experience in the travel industry began when he left his native London and first went to sea. Peter worked as

Expedition Leader on ships to some of the remotest places in the world. He has traveled to all seven continents and has led previous expeditions to Africa, receiving praise for his knowledge, leadership skills, and charm.



Born and raised in Zimbabwe, **Lyn Mair** is an ornithologist who has made Cape Town her home for the past 25 years. The senior author and photographer of *Seychelles*, the Bradt Travel guide, as well as other articles

on nature and wildlife, Lyn is familiar with practically every corner of Africa. During our cruises, Lyn will share with travelers her knowledge of and love for the amazing biodiversity of Africa and the places we will visit.



Dr. Donald Wright is Professor of History, Emeritus, at the State University of New York, Cortland. Contributor to *The Atlantic World: A History* and author of *The World and a Very Small Place in Africa*, Don recently

accompanied a similar voyage to the countries on this itinerary, lecturing on the slave trade, colonial influences, and modern politics. His research and travel in Africa has been sponsored by Fulbright-Hays and the National Endowment for the Humanities.



IN *the* WAKE of the EXPLORERS

Our voyage follows the route of the first European explorers. In search of a sea route to India, Portuguese navigators followed the coastline of West Africa, each one going a bit further, until in 1498 Vasco da Gama successfully rounded the Cape of Good Hope and came ashore in India.

Among the other explorers we'll learn of along the way are Mungo Park (1771-1806), a Scots surgeon who charted the Niger River; Mary Kingsley (1862-1900), who led expeditions to West Africa and was the first European to explore the remote regions of Gabon; and Alvise de Cadamosto (c1432-c1488), a Venetian who became the first European to reach the mouth of the Gambia River.

Vasco da Gama

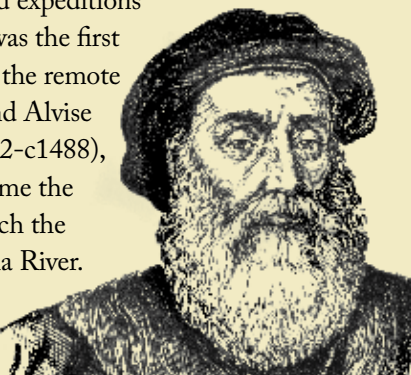

FROM CAPE TOWN *to* GHANA'S GOLD COAST

**FREE
ROUND-TRIP
AIRFARE!**
SEE PAGE 18

Itinerary

Sunday, February 17, 2013 • **FLY FROM USA**

Monday, February 18 • **CAPE TOWN, South Africa | EMBARK**

Arrive in Cape Town and transfer to the port to embark *Corinthian*. The striking combination of coastal and mountain geography of the famed Cape Peninsula, on which the city is built, makes Cape Town one of the world's most attractive cities. Overnight aboard, conveniently docked near the center of the city. (D)

Tuesday, February 19 • **CAPE TOWN | CAPE OF GOOD HOPE NATURE RESERVE and KIRSTENBOSCH NATIONAL BOTANICAL GARDEN | CAPE TOWN**

Travel through rolling hills to the Cape of Good Hope Nature Reserve and the lovely Kirstenbosch National Botanical Garden. Alternatively, explore South Africa's celebrated wine lands, including charming Stellenbosch, with its historic buildings and oak-lined streets. Sail this afternoon. (B, L, D)

Wednesday, February 20 • **AT SEA** (B, L, D)

Thursday, February 21 • **LUDERITZ | KOLMANSKOP | LUDERITZ, Namibia**

One of the first recorded European visitors to Luderitz was the great Portuguese explorer Vasco da Gama who sought shelter here in 1487. Later Luderitz became a thriving German colony, and today, the Bavarian architecture is unmistakable. Drive through the desert to the ghost diamond mining town of Kolmanskop, whose standing buildings give an insight into the area's diamond boom years. (B, L, D)

Friday, February 22 & Saturday, February 23 • **WALVIS BAY**

From Walvis Bay, explore Namib Desert Park, with its incredibly beautiful sand dunes, home to some of the oldest desert landscapes in the world. Learn about the natural life of the desert and enjoy a private dinner in the dunes. Also explore the wetlands around Walvis Bay, which comprise perhaps the most important bird sanctuary in Southern Africa. Over 150,000 birds are found here, including flamingoes, chestnut-banded plovers, curlew sandpipers, and others. (B, L, D)

Sunday, February 24 & Monday, February 25 • **AT SEA** (B, L, D)

**February 17 -
March 8, 2013**

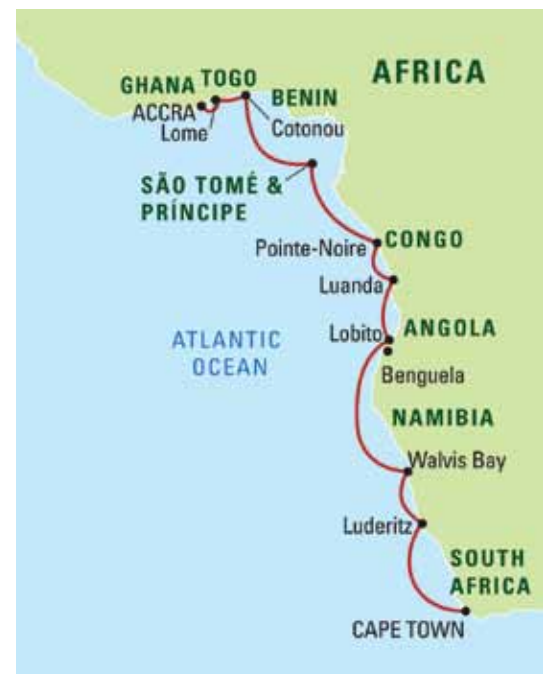

Traditional homes along our route



IN *the* REALM of the KINGS of the SKY

According to tradition, the Ogisos, the legendary Kings of the Sky, founded the Benin Empire (1440-1897). In addition to being a military power, Benin was also a center of superb art, particularly ivory sculptures and plaques of bronze and brass. After the arrival of the Europeans in the 15th century, Benin artists created works of art that depicted the newcomers.

In the 1890s, Great Britain pressured the Oba to become a protectorate of the British Empire. When the Oba rejected the proposal, a British military force invaded Benin, overthrew the Oba, and created the colony of Nigeria.

Tuesday, February 26 • **LOBITO | BENGUELA | LOBITO, Angola**

Take an excursion to Benguela, Angola's cultural capital. Founded by the Portuguese in 1617, Benguela retains much of its colonial architecture, including the church of Nossa Senhora do Pópulo, built in 1748, and the Pálacio do Governo, facing the sea. (B, L, D)

Wednesday, February 27 • **LUANDA**

Arrive in Luanda, Angola's capital, founded by the Portuguese in the 16th century. Guarding the port's entrance is Fortaleza de São Miguel, a fortress built in 1576, which we will visit along with other city sites. Alternatively, take an excursion to Kissama National Park, a coastal savannah that is home to rich wildlife. (B, L, D)

Thursday, February 28 • **POINTE-NOIRE, Congo**

Congo's main port, Pointe-Noire, is an appealing city thanks primarily to the wealth generated by offshore oil. Drive through typical villages and scenic countryside to visit the Diosso Gorge, with its red rock cliffs draped by the green of the jungle. Also explore the nearby museum, exhibiting objects relating to Congolese history, archaeology, and culture. (B, L, D)

Friday, March 1 • **AT SEA (B, L, D)**

Saturday, March 2 • **SÃO TOMÉ, São Tomé and Príncipe**

São Tomé was the prized island of the Portuguese from the 15th century until 1975, when it and the nearby island of Príncipe gained independence and formed the Democratic Republic of São Tomé and Príncipe. Call at the capital and main port, also called São Tomé, a picturesque and friendly town featuring colonial architecture. Also explore the lush interior, known for its rich biodiversity, and visit an active coffee plantation, where you'll observe a lifestyle largely unchanged since the colonial era and where you'll also sample some of their coffee. (B, L, D)

Sunday, March 3 • **PRÍNCIPE**

The smaller of the two-island nation of São Tomé and Príncipe, Príncipe features an impressive landscape of volcanic peaks covered with dense forest. Beautiful beaches with incredibly clear water line this tropical paradise. Stroll in the charming colonial town of Santo Antonio, walk through the abandoned plantation of Porto Real, watch villagers make palm oil, or hike through the pristine rain forest. (B, L, D)



An alfresco dinner amid the dunes of the Namib Desert



The tranquil island of Príncipe

Monday, March 4 • AT SEA (B, L, D)

Tuesday, March 5 • COTONOU | PORTO-NOVO | COTONOU, Benin

The small country of Benin, home to an ancient sophisticated culture, is emerging as a popular travel destination. From Cotonou, drive to the nearby capital, Porto-Novu, set on green hills surrounding a large lagoon. Formerly the center of an indigenous prosperous kingdom, it later became the capital of the French colony of Dahomey. Explore the Ethnography Museum and the restored palace of King Toffa. After lunch, board local motorboats to ride across Lake Nokoué to the picturesque fishing village of Ganvié, built on stilts. (B, L, D)

Wednesday, March 6 • LOME | AGBODRAFO | LAKE TOGO | LOME, Togo

For centuries Togo was part of several empires, later becoming part of the French and German colonial empires. Tour Lome, Togo's friendly capital and one of West Africa's most exciting cities, including the handicraft markets, with traditional goods from all over West Africa and noted for sculpture and batiks. Then drive to Agbodrafo (the former Porto Seguro), set on the shores of Lake Togo, to explore the lake's traditional villages by local pirogues. (B, L, D)

Thursday, March 7 • TEMA | DISEMBARK | ACCRA, Ghana | FLY TO USA

Disembark in Tema, the port of Accra, Ghana's capital, which we will explore, including the excellent crafts market and the National Museum of Ghana, with its fine collections. Transfer to the airport for flights home. (B)

Friday, March 8 • ARRIVE IN USA

WALVIS BAY, NAMIBIA

One of the most remarkable sites of our voyage is Namibia's Walvis Bay, a large lagoon and the most important wetland in southern Africa. The bay is the habitat for thousands of pelicans, flamingoes, and migrating birds, including European oystercatchers, black-tailed godwit, and common redshank. Beyond the lagoon lie the magnificent sand dunes of the Namib Desert, where we have arranged something very special: while you are exploring the lagoon and the dunes, we will have large tents set up and furnished with tables and chairs for an alfresco dinner in the desert.

FROM GHANA'S GOLD COAST *to* the STRAIT of GIBRALTAR

**FREE
ROUND-TRIP
AIRFARE!**
SEE PAGE 18

March 5 - 24, 2013

Itinerary

Tuesday, March 5, 2013 • **FLY FROM USA**

Wednesday, March 6 • **ACCRA, Ghana**

Arrive in Accra, the capital of Ghana, founded around 1500 as a post trading with Europeans in gold, palm oil, and other commodities. Overnight at the *Labadi Beach Hotel*.

Thursday, March 7 • **ACCRA | TEMA | EMBARK**

Check out of the hotel and explore Accra, including the excellent crafts market and the National Museum of Ghana, with its fine collections. Transfer to Tema, the city's port, to embark on *Corinthian* and sail. (B, L, D)

Friday, March 8 & Saturday, March 9 • **TAKORADI, THE CASTLE COAST & KAKUM NATIONAL PARK**

The center of the "Castle Coast," Takoradi is our gateway to two of Ghana's most important sites, the Kakum National Park and the historic forts built by the colonial powers starting in the 15th century. Kakum is an extensive rain forest with a rich wildlife, including colobus monkeys, over 300 species of birds, and some 600 varieties of butterfly. Walk the 1,000-foot aerial walkway through the forest canopy. On the coast, visit the Cape Coast Castle, built by the Dutch in 1637, now a UNESCO World Heritage site. (B, L, D)

Sunday, March 10 & Monday, March 11 • **AT SEA** (B, L, D)

Tuesday, March 12 • **FREETOWN, Sierra Leone**

With its lush forests, nature reserves, and white-sand beaches, Sierra Leone is one of West Africa's most attractive destinations. Tour Freetown, the country's capital, including the Sierra Leone Museum, St. George's Cathedral (1828), and the city's colorful markets. Also visit the picturesque Regent Village, with its early 19th-century Krio-style houses, and the Tacugama Chimpanzee Sanctuary. Alternatively, travel to Bunce Island. Located up the Sierra Leone



Musicians in Dakar playing the stringed kora, part of Senegal's rich musical tradition



The distinctive architecture of Marrakech, Morocco



West Africa abounds in traditional craft markets

River, Bunce is known for its enormous slave fort, built in 1670 by the British, now a UNESCO World Heritage site. (B, L, D)

Wednesday, March 13 • AT SEA (B, L, D)

Thursday, March 14 • BANJUL | ABUKO NATURE RESERVE | MAKASUTU CULTURE FOREST | BANJUL, The Gambia

Founded by the British early in the 19th century, Banjul is the capital and commercial center of The Gambia. Drive to the Abuko Nature Reserve, one of the last surviving examples of tropical riverine forests in the country. Within its confines are about 300 species of birds, as well as red colobus and callithrix monkeys. Continue to the Makasutu Culture Forest, a private nature habitat with beautiful woodland and waterways. (B, L, D)

Friday, March 15 & Saturday, March 16 • DAKAR, Senegal

Spend two days in Senegal's beautiful capital city, Dakar. With its strong French influence, it is also a center of African arts and culture. Our exploration of this vibrant city includes the Museum of African Art, one of the continent's best, and the artisan market, among other sites. A short ferry ride brings us to Gorée, a UNESCO-protected island, with narrow alleyways and characteristic pastel mansions. (B, L, D)

Sunday, March 17 • AT SEA (B, L, D)

Monday, March 18 • DAKHLA, Western Sahara, Morocco

The former capital of the Spanish colony of Rio de Oro, Dakhla is the southernmost town of Western Sahara, located on a long peninsula jutting into the Atlantic. Whitewashed houses characterize this friendly town. Enjoy a tour of the city and a drive north through the scenic peninsula, which is flanked on one side by the Atlantic and by a tranquil bay on the other. (B, L, D)

Tuesday, March 19 • LAAYOUNE

From the port of El Marsa, drive inland across Saharan dunes to reach Laayoune, the main city in Morocco's Western Sahara. Explore the Spanish-Saharan architecture of the city's old district, the Museum of Traditional Arts, and the Artisans' Center's craft workshops. (B, L, D)



Fisherman along the unspoiled coast of Sierra Leone

THE TACUGAMA CHIMPANZEE SANCTUARY, SIERRA LEONE

This sanctuary and rehabilitation program began in 1988 when Bala and Sharmila Amarasekaran rescued a sick baby chimp. From that small beginning grew the Tacugama Chimpanzee Sanctuary, which, over the years, has rescued hundreds of orphaned and kidnapped chimpanzees. At Tacugama the chimps receive medical treatment and live in semi-wild enclosures where they can form the social units that are essential to a chimpanzee's well-being. The staff and supporters of Tacugama are also active in advocating the enforcement of local and international legislation that bans the trade in chimpanzees.



Kakum National Park's aerial walkway soars above the floor of the rain forest in Ghana

KAKUM NATIONAL PARK, GHANA

More than 200 species of birds and 400 species of butterflies make their home in Kakum National Park. Most of them dwell high in the canopy of this virgin rain forest, which makes it difficult for visitors to see them from the forest floor. The solution: a canopy walkway. Suspended more than 130 feet above the ground and 1,000 feet long, the walkway takes you into the habitat of the birds and butterflies, giving you an unforgettable experience.

Wednesday, March 20 • AT SEA CRUISING ALONG THE COAST OF MOROCCO (B, L, D)

Thursday, March 21 • SAFI | MARRAKECH | SAFI

From Safi, drive to fabled Marrakech, one of Morocco's four Imperial Capitals, founded in the 11th century and set among gardens and palm groves. Our exploration includes the 12th-century Koutoubia Minaret, the Bahia Palace, the Ben Youssef Medressa, the Jewish Quarter, and Djemaa el-Fna, the city's central square at the heart of the Medina. There will also be the opportunity to walk through Marrakech's colorful souks. (B, L, D)

Friday, March 22 • CASABLANCA

Dock in Casablanca, Morocco's largest port city and commercial center. Tour the city, including the vast Hassan II Mosque, built on a promontory facing the sea. Overnight aboard docked in port. (B, L, D)

Saturday, March 23 • CASABLANCA | RABAT | CASABLANCA

From Casablanca, drive to Rabat, Morocco's elegant capital. Tour Rabat's main sites, including its Medina. Within the Medina are colorful souks, the Kasbah des Oudaias, the evocative quarter of the old Almohad, the Chellah Citadel, and Merenid and Andalusian towns. (B, L, D)

Sunday, March 24 • MALAGA, Spain | DISEMBARK | FLY TO USA

Disembark in Malaga and transfer to the airport for return flights home. (B)

**FREE
ROUND-TRIP
AIRFARE!**

SEE PAGE 18

MAKE *it a* JOURNEY *of a* LIFETIME, A GRAND AFRICA ODYSSEY

Combine the two voyages to cruise from Cape Town to Malaga, giving yourself a journey of a lifetime. With its spacious accommodations, wide open deck spaces, fine facilities, superb cuisine and service provided by almost as many crew members as there are guests *Corinthian* is the ideal cruise ship for long voyages of discovery. And by combining the two voyages, you will save over the rates of the individual cruises.

GRAND VOYAGE

February 17 – March 24, 2013

Walvis Bay in Namibia, backed by striking scenery, is home to large colonies of birds, including flamingoes





CORINTHIAN — THE IDEAL

A RETURN *to* ELEGANCE

Launched in early 2009 after extensive refurbishment, redecoration, and other improvements, the all-suite *Corinthian* offers the finest in small-ship cruise travel. Taken together with her limited guest capacity, and excellence of design, craftsmanship, and material, *Corinthian's* spaciousness and intimate ambience combine to make her ideal for distinctive cultural and expedition voyages.

This private yacht-like cruise ship accommodates only 100 guests in 50 suites, each of which affords sea views, measures 215 square feet or more, and is appointed with two twin-size beds that can convert to a queen-size bed, a sitting area or separate living room, climate control, spacious closets, mini-refrigerator, safe, telephone, TV, DVD/CD player, Internet connection, and bathroom with marble vanity, teak floor, shower, and other amenities. Guests staying in the spacious Penthouse Suites and Veranda Suites (260 and 245 square feet, respectively) will also enjoy a private balcony, private butler service, and other exclusive in-suite amenities.

INVITING FACILITIES *and* ATTRACTIVE AMENITIES

Public facilities include a restaurant that accommodates guests at a single, unassigned seating, two lounges, expansive library with Internet access, gym, spa, beauty salon, boutique,



The Club

Jacuzzi, doctor's office, and ample deck areas for relaxing and sunbathing. An elevator serves all decks. *Corinthian* complies with the latest international and U.S. Coast Guard safety regulations and is outfitted with the most current navigational and communications technology as well as with retractable fin stabilizers for smooth sailing and a fleet of Zodiac boats for excursions ashore. *Corinthian* is staffed by 67 officers and crew.



Veranda Suite

SHIP *for this* VOYAGE *of* DISCOVERY



Spa



Category C Suite



Restaurant



Sun Deck

PROGRAM INCLUSIONS

- Free round-trip air from New York as noted below
- Cruise aboard the all-suite, 100-guest *Corinthian*
- One night at the *Labadi Beach Hotel* in Accra (only on the March 5-24 voyage)
- Complete program of tours and excursions
- Welcome and farewell cocktail receptions aboard ship
- All meals aboard ship, including house wine, beer, and soft drinks with lunch and dinner
- Open bar aboard ship throughout the cruise
- Enrichment program of lectures and discussions by accompanying naturalists and lecturers
- Professional Travel Dynamics International tour staff
- Complete pre-departure materials
- Baggage handling and transfers abroad on the designated program arrival and departure dates
- Port and embarkation taxes
- Gratuities to porters, guides, and drivers

NOT INCLUDED: Airfare other than free round-trip airfare from New York as noted below; visa and passport fees (if applicable); luggage and trip cancellation insurance; meals, soft drinks, and alcoholic beverages other than those specified above; personal expenses such as laundry, telephone calls, faxes, and e-mail service; and gratuities to shipboard personnel

FREE AIRFARE

Free round-trip economy class airfare from New York will be provided on all voyages described in the brochure.

If you wish to make your own air arrangements, a credit of \$1,200 will be provided. Airfare from most other U.S. cities available at the additional cost of only \$99 to \$199 per person.

FREE ROUND-TRIP AIRFARE!

DECK PLAN

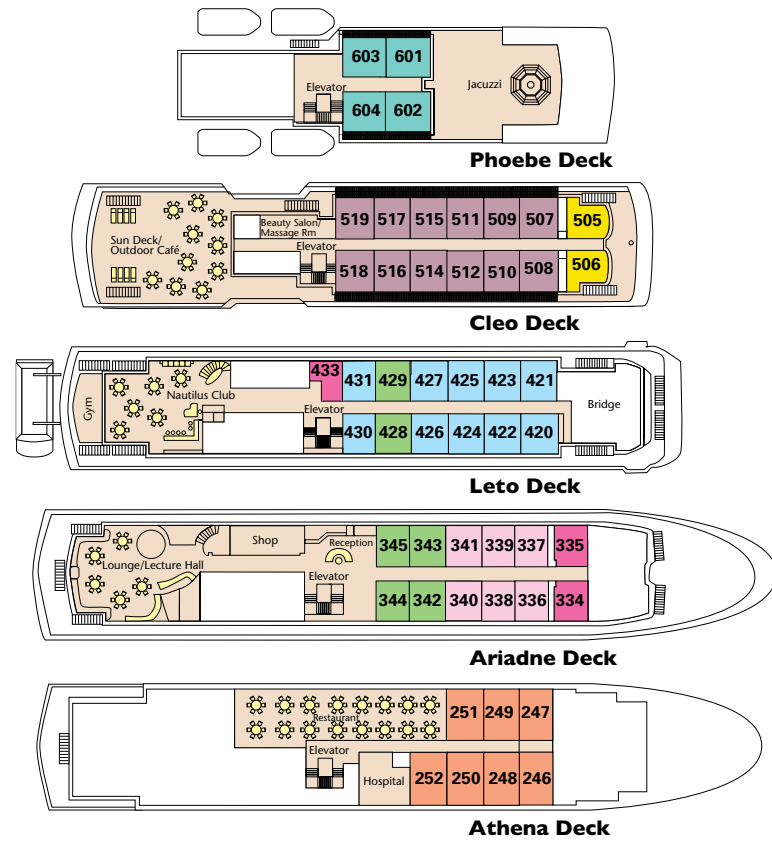

NO SINGLE SUPPLEMENT
 A limited number of cabins have been designated for single travelers in Categories C - A at no supplement to the per person, double occupancy rates.

CRUISE AND LAND RATES | PER PERSON, DOUBLE OCCUPANCY

All accommodations aboard *Corinthian* are suites. They face outside, affording sea views, and include a bedroom with two twin-size beds that can convert to a queen-size bed, sitting area, mini-refrigerator, safe, spacious closets, climate control, telephone, TV, DVD/CD player, Internet connection, and bathroom with marble vanity, shower, and other amenities.

CATEGORY	DESCRIPTION	RATES for Cape Town/ Accra or Accra/ Malaga	RATES FOR GRAND AFRICA ODYSSEY
E	Deluxe suites on Ariadne and Leto Decks with windows and sitting area. 215 sq. ft. Suites *342 - *345, *428, *429*PARTIALLY OBSTRUCTED VIEW	\$14,995	\$26,995
D	Deluxe suites on Ariadne and Leto Decks with window and sitting area. 215 sq. ft. Suites 334 - 335, 433	\$15,995	\$29,995
C	Deluxe suites on Athena Deck with portholes and sitting area. 275 sq. ft. Suites 246 - 252	\$16,995	\$31,995
B	Deluxe suites on Ariadne Deck with windows and sitting area. 225 sq. ft. Suites 336 - 341	\$17,995	\$33,995
A	Deluxe suites on Leto Deck with window and sitting area. 235 sq. ft. Suites 420 - 427, 430 - 431	\$18,995	\$35,995
AA	Deluxe suites on Cleo Deck with forward windows and sitting area. 285 sq. ft. Suites 505 - 506	\$20,495	\$38,995
VS	Deluxe Veranda Suites on Cleo Deck with private balcony and sitting area. 245 sq. ft. Suites 507 - 519	\$22,995	\$42,995
PHS	Deluxe Penthouse Suites on Phoebe Deck with private balcony and sitting area. 260 sq. ft. Suites 601 - 604	\$24,595	\$47,995
VS & PHS suites are provided with private butler service and other exclusive amenities.			

GENERAL INFORMATION

Payment Schedule: An initial deposit of 10% of the trip cost (per person) is required to reserve your space on the tour. For your convenience, you may charge your initial deposit to your American Express, Visa, Discover, or MasterCard or pay it by check. Final payment is due 90 days prior to departure and is payable only by check. Credit cards are not accepted for final payment. Personal checks are accepted for both initial deposit and final payment.

Cancellations & Refunds: All cancellations of confirmed reservations are subject to a \$300 per person administrative fee. Additionally, passengers are subject to any cancellation fees assessed by the purveyors of services, including airlines or hotels used in the itinerary. Cancellations received 61-90 days prior to departure will be assessed a penalty equal to 50% of the total program cost per person. Cancellations received within 60 days of departure are subject to 100% cancellation penalties. Requests for cancellations must be made in writing. No refunds will be made for any part of this program in which you choose not to participate. Service fees may apply to deviations and are non-refundable.

Insurance: We strongly recommend the purchase of trip cancellation insurance, which is available for coverage of expenses in conjunction with cancellation due to illness or accident. Baggage insurance is also recommended. In the event that you must cancel your participation in a travel program, trip cancellation insurance may be the only source of reimbursement. You may enroll with Travel Dynamics International's insurance carrier, Travelex, or you may obtain coverage through a company of your choice. If you choose to purchase travel insurance from Travelex, we have negotiated a special insurance policy for this program. After your initial trip deposit, you would pay an insurance premium based on only 10% of the trip cost. The 10% insurance premium is fully refundable up to nine months prior to departure. Final payment of the insurance premium is due 90 days prior to departure (which is the same time your final trip payment is due.)

Itinerary: The itinerary, accommodations, and arrangements are subject to change at the discretion of Travel Dynamics International.

Responsibility: Please read carefully the following terms and conditions, which constitute the sole, legally enforceable agreements between the passenger and Travel Dynamics International and the tour's sponsoring organization. The passenger is also advised to review his/her separate ticket passage contract with the vessel's owner/operator, which will constitute the sole, legally enforceable terms of carriage for this tour and is available on request from Travel Dynamics International. Travel Dynamics International and the tour's sponsoring organization act solely as agents for the passenger with respect to all transportation, hotel and other tour arrangements. In that capacity, we exercise all reasonable care possible to ensure the passenger's safety and satisfaction, but, we neither assume nor bear any responsibility or liability for any injury, death, damage, loss, accident, delay or irregularity arising in connection with the services of any ship, airplane, train, automobile, motor coach, carriage or other conveyance, or the actions of any third-party, involved in carrying the passenger or in affecting these tours. We are not responsible for damages, additional expenses, or any other losses due to cancellation, delay or other changes in air or other services, sickness, weather, strike, war, civil disturbances, acts or threats of terrorism, travel warnings or bans, termination or suspension of war risks or other carrier insurance, quarantine, acts of God or other causes beyond our control. All such losses must be borne by the passenger, and tour rates provide for arrangements only for the time stated. In the event of cancellation, delay or rescheduling mandated by any of the aforesaid causes beyond our control, the passenger shall have the option of accepting in lieu of the original tour such rescheduled tour or other substituted tour(s) as may be offered by us, or else, receiving a refund of as much of such advance tour expenditures as we are able to recover on the passenger's behalf from carriers, third-party tour vendors, etc., but, we shall not have any obligation or liability to the passenger beyond the foregoing. We reserve the right to make alterations to the tour's itinerary and to substitute hotels, ships, or lecturers if this is required. We reserve the right to cancel, delay, or reschedule any tour prior to departure, and, so long as this is not due to any of the aforesaid causes beyond our control, the passenger shall be entitled to a full refund of all monies paid to that point if he/she so desires. No refund shall be made for any unused portion of any tour. By forwarding their deposit(s), the passenger certifies that he/she and/or their dependents, minors or others covered thereby do not have any mental, physical or other condition of disability that could create a hazard for them or other passengers. We reserve the right to decline to accept or to decline to retain any person as a member of any tour should such person's health, condition or actions adversely affect or threaten the welfare or safety of other passengers or impede the tour. Baggage or valuables brought on the tour shall be transported, handled or stored at the passenger's risk entirely, and, we shall bear no liability or responsibility for any damage or other loss thereto. Passenger tickets are not transferable and are not subject to alteration by the passenger. No suit shall be maintainable against the carrier, or vessel, for any losses, accidents, damages to person, property, personal injury (including death or other types of bodily injury) of the passengers, unless written notice of the claim, with full particulars, is delivered to the carrier or its agents at its office at the port of sailing or at the port of termination within six months from the day when such incident occurred. In no event shall any such suit or any claim against the carrier or vessel for any losses, accidents, damages to person, property, personal injury (including death or other types of bodily injury) of the passenger be maintainable unless such suit is commenced within one year from the day when the incident causing such losses, accidents, damages to person, property, personal injury (including death or other types of bodily injury) of the passenger occurs, notwithstanding any provision of law of any state or country to the contrary. Resolution of any disputes arising hereunder shall be brought within the United States District Court for the Southern District of New York, pursuant to the applicable general maritime law, and applying the applicable general maritime law and Federal maritime statutes.

Rates: Tour costs are based upon current airfares, tariffs, and currency values. While we do everything possible to maintain the listed prices, they are subject to change.

Fuel Supplement: Travel Dynamics International reserves the right to charge a fuel supplement, without prior notice, if the NYMEX oil price exceeds \$85 per barrel. This supplement may be charged even if the cruise fare has been paid in full.

Ship's Registry: Malta

CST #204 3599-40 TDI



A gemsbok in the Namib Desert

REGISTRATION

JOHN 13201

Enclosed is my check or credit card no. for \$_____ (10% of the rate per person) as a deposit to hold _____ place(s) on *Into Africa*. I understand that final payment is due ninety (90) days prior to departure and is payable by check only. Credit cards are not accepted for final payment.

Please make check payable to and mail with this registration form to:
Travel Dynamics International, 132 East 70th Street, New York, NY 10021

AmEx Discover Visa MasterCard

No. _____ Exp. ____ 3- or 4-Digit Security Code _____

Please select cabin category in order of preference:

PHS__ VS__ AA__ A__ B__ C__ D__ E__

Twin Beds Double Bed
 Single Occupancy Share (cannot be guaranteed)

Please select your preferred departure date:

SHORTER SEGMENTS

February 17 – March 8, 2013 (Cape Town to Accra; Tour 13201B)
 March 5 – 24, 2013 (Accra to Malaga; Tour 13201C)

GRAND VOYAGE

February 17 – March 24, 2013 (Cape Town to Malaga; Tour 13201)

Eligibility: At least one member of the traveling party is required to make a sustaining financial contribution of \$50 or more to the Johns Hopkins Alumni Association within the fiscal year. Please visit alumni.jhu.edu/support.

Note: A small portion of the cost of your trip supports the Johns Hopkins Alumni Travel Program.

DR./MR./MRS./MS. FIRST LAST

DR./MR./MRS./MS. FIRST LAST

ADDRESS

CITY/STATE/ZIP

TELEPHONE (DAY) (EVENING)

E-MAIL

Each participant must sign below: I/We have read the "General Information" section and agree to its terms.

SIGNATURE DATE

SIGNATURE DATE

JOHNS HOPKINS

UNIVERSITY

Office of Alumni Relations

San Martin Center, Second Floor
3400 N. Charles Street
Baltimore MD 21218-2696
410-516-0363 / Fax 410-516-6858
1-800-JHU-JHU1

**FREE
ROUND-TRIP
AIRFARE!**

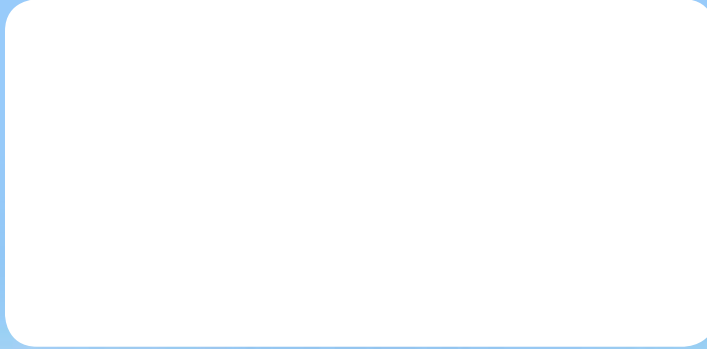

PSRST STD
U.S. Postage
PAID
Travel Dynamics
Int'l



The vast sand dunes of the Namib Desert

EXPLORE *the* “UNDISCOVERED” AFRICA *on a* JOURNEY *of a* LIFETIME



The splendid Kirstenbosch National Botanical Garden, South Africa



Orange-breasted sunbird

For reservations or further information,
please contact

TRAVEL DYNAMICS INTERNATIONAL
toll-free at **800-257-5767** or
JOHNS HOPKINS ALUMNI
at **800-548-5481**

(Monday - Friday, 9:00 a.m. - 5:00 p.m. Eastern Time).

JOHN 13201